

PM-PAG-100

PNEUMATIC ANGLE SANDER

Wheel Dia:100MM
Free Speed:11000RPM
Air Inlet (NPT):1/4"
Air Hose(ID):3/8"
Avg.air consumption:5cfm, 140 L/min
Sug.Air Comp:2HP
Net Weight:1.3kg

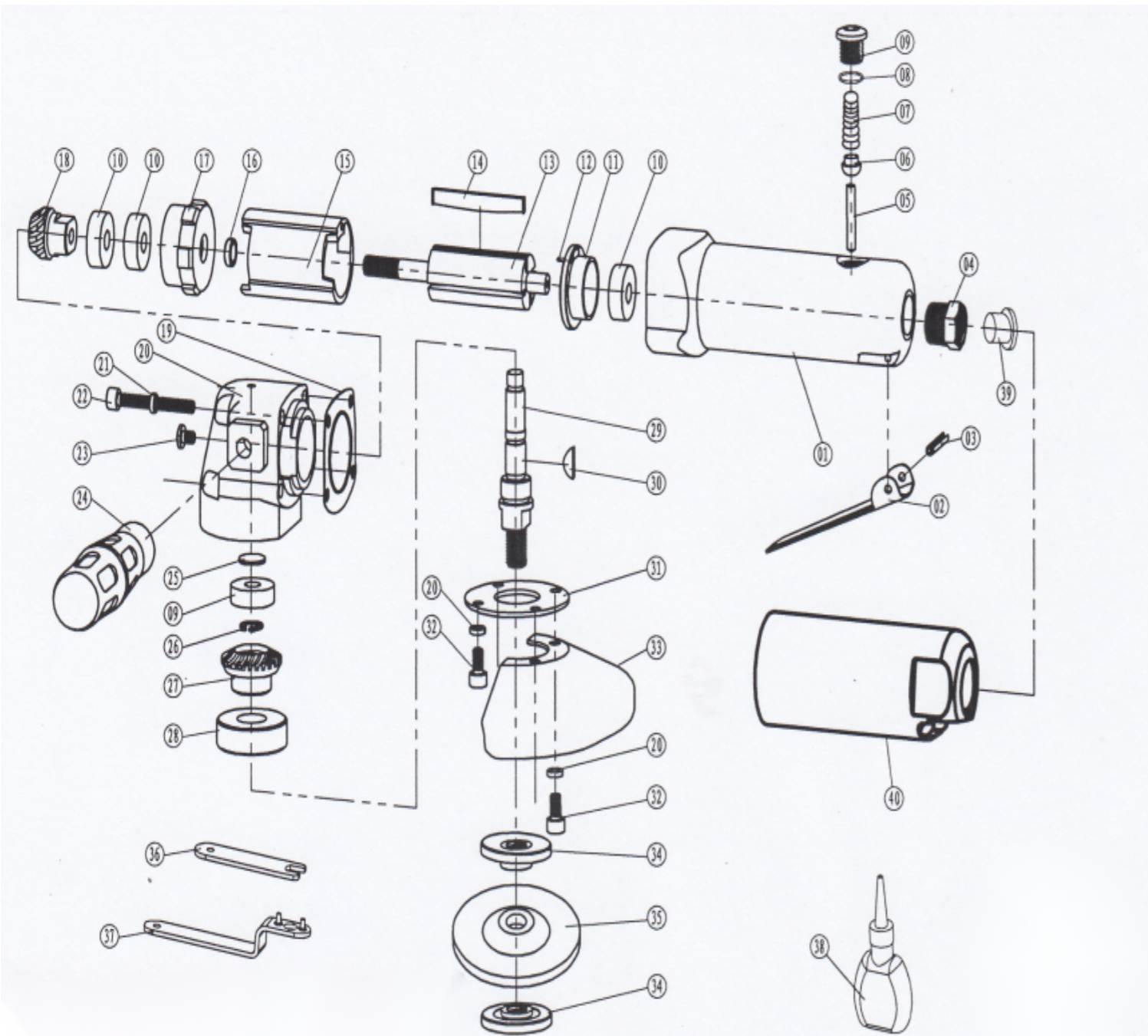

No.	Part Description	Qty.	Seri No	INR
1	Sanding pad	1		
2	Main Shaft	1		
3	Retainer ring	1		
4	Bearing washer	1		
5	Bearing	1		
6	Bearing	1		
7	Drive shaft	1		
8	Woodruff Key	1		
9	Lock ring	1		
10	O-ring	1		
11	Bearing	1		
12	Front cover	1		
13	Rotor	1		
14	Rotor blade	5		
15	Pin	1		
16	O-ring	1		
17	Cylinder	1		
18	Rear cover	1		
19	Bearing	1		
20	Retainer ring	1		
21	Protective shield	1		
22	Housing	1		
23	Housing sheath	1		
24	Pin	2		
25	Trigger	1		
26	O-ring	2		
27	Vacuuming joint	1		
28	Locked pipe	1		
29	Vacuuming straight pipe	1		
30	Vacuuming bend pipe	1		
31	Switch Plug	1		
32	Reverse pin	1		
33	Spring	1		
34	O-ring	1		
35	Air inlet connection	1		
36	O-ring	1		
37	Switch pole	1		
38	O-ring	1		
39	Adjust Knob	1		
40	Retainer ring	1		

